



passive fire protection and insulation

Suppliers of passive fire products,
acoustic and specialist insulation
Manufacturers of the Safire® Fire Stopping Range

Uniclass	EPIC
CI/SIB	

Safire® Flamestop FSI 30/120

Lightweight Fire Cavity Barrier

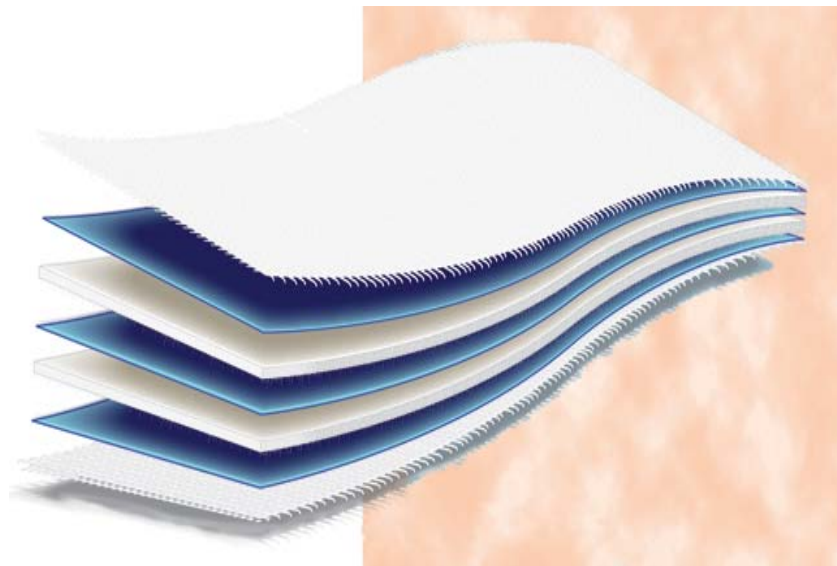

30
mins
insulation

120
mins
integrity

WF Assessment Reports
No. 168737 & 163318



Safire® Flamestop FSI is a high performance, lightweight fire cavity barrier designed to stop smoke and flame, and also to insulate against heat transfer and the possible ignition of materials on the cold side of the barrier.

Safire® Flamestop FSI is used to compartmentalise structures within roof voids and above suspended ceilings.

- Lightweight
- Versatile
- Easily modified
- Tested to BS 476: Part 20/22
- Waterproof
- Simple to fix
- 120mins integrity
- 30mins insulation



3 foil layers interleaved with high temperature glass fibre construction



Flamestop FSI undergoing fire test at Bodycote Warrington Fire

FLAMESTOP FSI 30/120

Lightweight Fire Barrier

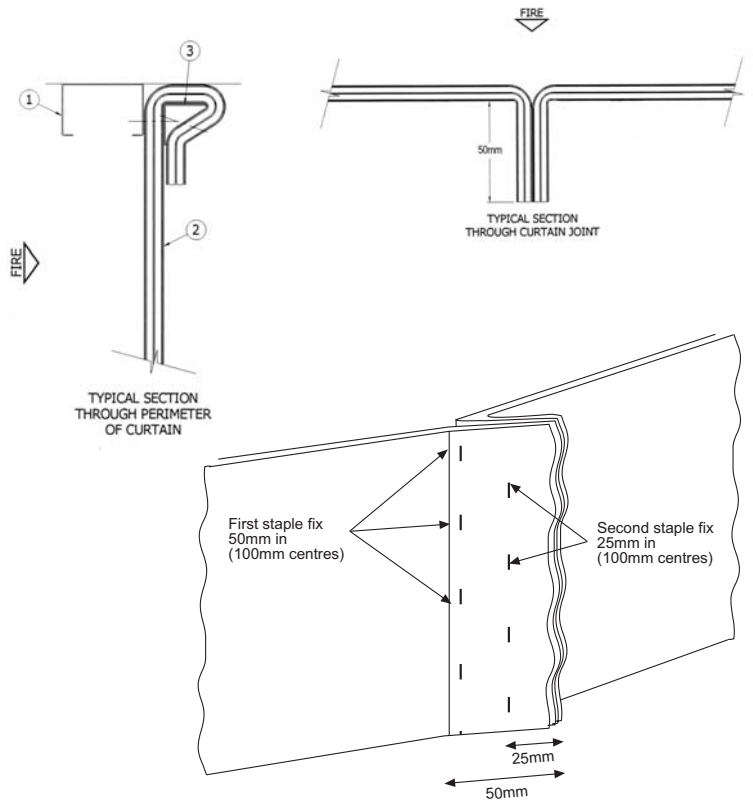

Standard roll size: 1.3m wide x 7m long

Installation: easily installed using plain galvanised angle 25mm x 25mm, 50mm C-stud, staple gun and standard fire screw fixings.

Separate installation instructions sheet available on request.



Staple gun and staples are held in stock and available to order

Other products in the Fireus Products range:

FIRE BARRIERS: Total Comfort Rock Fibre Fire Blanket

FIRE STOPPING: Compound
Fire Collars
Barriers (Batts)
Sealants
Fire Pillows
Expansion Joints
Flamestop60

THERMAL: Industrial thermal and acoustic insulation

For information on any of the above, or the name of your nearest distributor, please contact our sales department on tel. 01524 388898.

Alternatively, product information is available from our web site at www.fireus.co.uk

Your distributor:



Fireus Ltd.

Unit 6 Thetis Road, Lune Industrial Estate, Lancaster, LA1 5QP

Tel. 01524 388898 | Fax. 01524 383724 | Email. info@fireus.co.uk | Web. www.fireus.co.uk

